



## Model: M2000 d.c.

### INSTRUCTIONS TO USER

Check motor voltage and frequency shown on identity label and ensure correct supply.

Motor leads to be terminated in accordance with relevant electrical safety standards by suitably qualified personnel.

Motor should be earthed.

Pump tubing will not last forever. Establish suitable tube replacement schedule to avoid inconvenient tube failure

**LIMIT OF USE** – These pumps should not be used in conjunction with life support equipment.

This pump should not be in anyway connected to the human body.

All the advantages of the original Autoclude patented tube loading system on a high quality low cost d.c. motor. The larger of the two pump family. Cartridge can be changed in seconds, no tools required. Ideal for slow speed pumping on intermittent or continuous duty cycles.



**Pump Head:** Black polycarbonate with support bearing and mounting plate.

**Rotor:** Polycarbonate with stainless steel inserts and Nylatron rollers (adjustable)

**Motor:** Permanent magnet 12/24v.d.c

**Tube** Autoprene® 8.0mm tube/cartridge assy

**/Cartridge:** Silicone 8.0mm tube/cartridge assy.

**Gearbox:** Spur

**Weight:** 1.4 Kg

M2000 DC P.M. - FLOW RATE INFORMATION			
RPM			
TUBE	85	125	176
8	688.5	1012.5	1425.6

All flow rates shown in ml/min

Identify required flow rate in above table and select largest tube size with slowest motor speed to achieve best tube life.



### Typical M2000 d.c. assembly dimensions

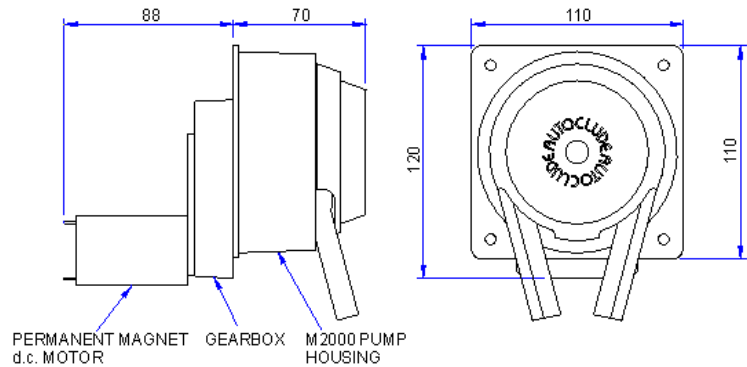

### M2000 STANDARD SPARES

PART NO	DESCRIPTION
AU E0017	Bearing 3/8"ID x 7/8"OD
AU E0037	Fan CCW nylon
AU E0074	Back plate
AU E0075 03	Housing
AU E0076 03	Rotor assembly complete
AU E0080	Cartridge retaining clip
AU E0066	Rotor setting jig

### TUBE CARTRIDGE ASSY

AU E0048 2CPA 08	8.0mm Autoprene cartridge
AU E0048 2CPS 08	8.0mm Silicone cartridge

### GUARANTEE

This product is guaranteed to be free from defects in material and workmanship for a period of 12 months from date of purchase. Products out of guarantee period will be repaired for a nominal charge.

For your protection items returned must be carefully packed to prevent damage in transit and insured against possible loss.



ARISDALE AVENUE, SOUTH OCKENDON, ESSEX RM15 5DP, ENGLAND

TELEPHONE: +44 (0) 1708 856125/6 FAX: +44 (0) 1708 857366

WEBSITE: [www.autocludepumps.com](http://www.autocludepumps.com)

E-MAIL: [info@autocludepumps.com](mailto:info@autocludepumps.com)